

BD 342 Inline USB Module

Applications

The USB module BD342 enables direct connection of a strain-gauge load cell to a PC. The USB module (BD 342) is equipped with the automatic sensor identification (TEDS). Thus sensors of different rated loads can be easily connected.



Special Features

- USB 2.0 interface
- Sampling rate up to 1600 values/ sec
- 0.01 % accuracy class
- Display and operation via **ASTAS**® software
- Supports TEDS

Dimensions/ Connections

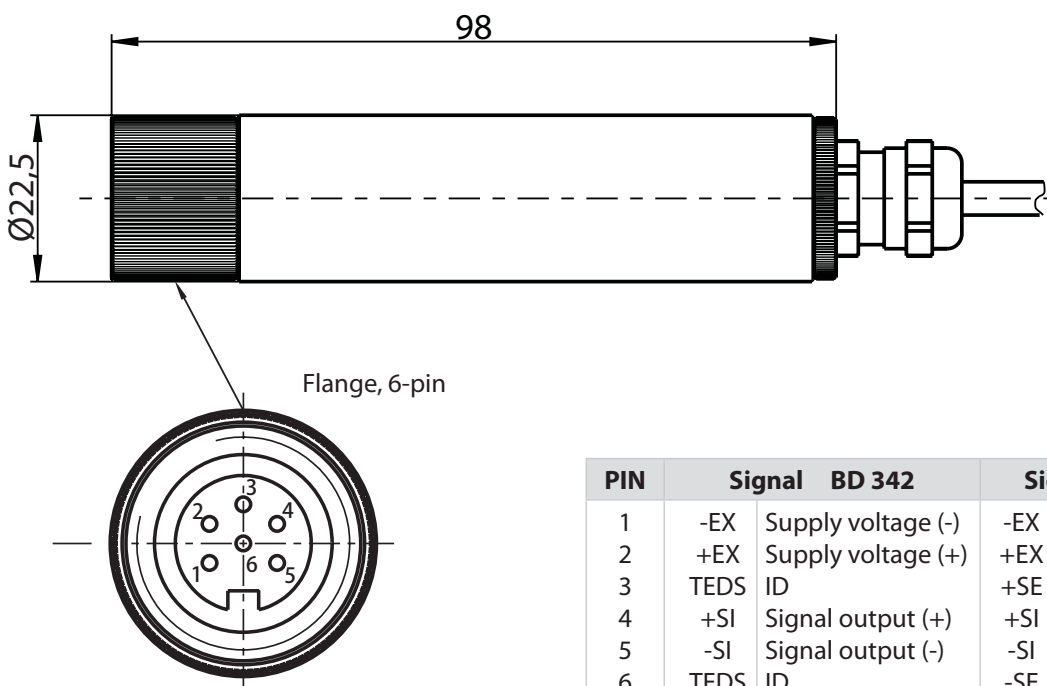



PIN	Signal	BD 342	Signal	BD 342-6L
1	-EX	Supply voltage (-)	-EX	Supply voltage (-)
2	+EX	Supply voltage (+)	+EX	Supply voltage (+)
3	TEDS	ID	+SE	Sense signal (+)
4	+SI	Signal output (+)	+SI	Signal output (+)
5	-SI	Signal output (-)	-SI	Signal output (-)
6	TEDS	ID	-SE	Sense signal (-)

Specifications

Input		Load Cell with Strain Gauge Full Bridge (350 Ohm)
Input signal range (=S*)	mV/V	0.3 ... 5
Sensor supply voltage	VDC	5
Internal resolution	piece	999.999 (22 bit at 2 mV/V)
Sampling rate (averaging)	1/sec	6.25 ... 1600
Measured value communication via USB		max. 1600 values/ sec with ASTAS software
Power Supply		
Voltage range	VDC	5 (via USB port)
Power consumption	mW	150
Environmental Conditions		
Operating temperature range	°C	-10...+50
Storage temperature range	°C	-20...+70
Error at S=2 mV/V		
Maximum linearity error	%	0.0015
Noise (at sampling rate)	%S	0.002 (6.25 Hz)...0.04 (1600 Hz)
Zero drift	%/10 K	0.002
Construction		
Weight	g	200
Dimensions	mm	98 x Ø 22.5
Environmental protection (EN 60529)		IP 65

*S = Measuring range end value

Order Example

Type Code	Description
BD 342	Inline USB module for sensors, software  download on www.ast.de
BD 342-6L	Inline USB module for sensors with 6-wire technique without TEDS, software  download on www.ast.de

Options

	Type Code	Description
Plugs	XKC 071	6 pin plug (TEDS)
	XKC 041.03	6 pin plug