

# Load Switch LS 804

Original  
Manual

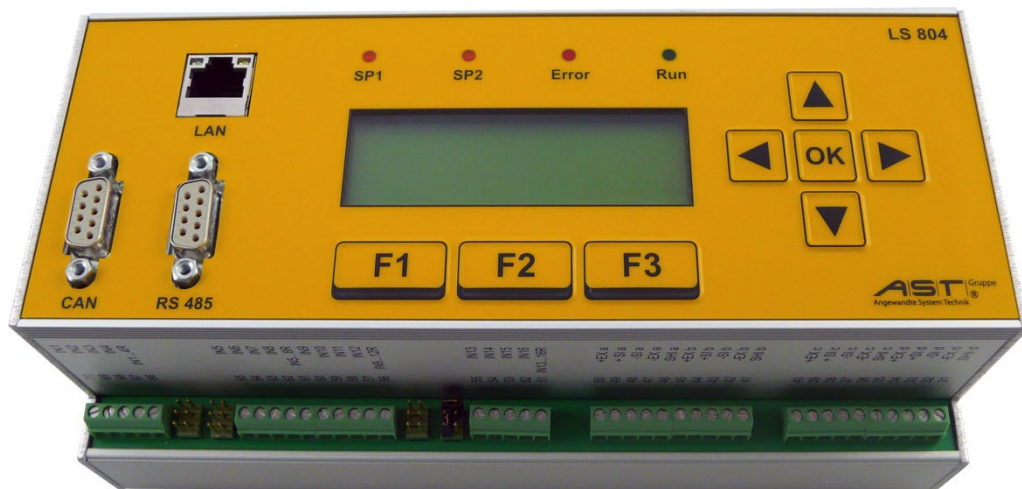

A.S.T. - Angewandte System Technik GmbH, Mess- und Regeltechnik

Marschnerstraße 26  
Phone (03 51) 44 55 30  
[www.ast.de](http://www.ast.de)

D-01307 Dresden  
Fax (03 51) 44 55 555  
vertrieb.dd@ast.de



## List of Contents

<b>1.</b>	<b>General description</b> .....	<b>1</b>
<b>2.</b>	<b>Functional description</b> .....	<b>1</b>
<b>3.</b>	<b>Dimensions</b> .....	<b>2</b>
<b>4.</b>	<b>Electrical connection</b> .....	<b>3</b>
4.1.	Connection diagram.....	3
4.2.	Voltage supply 24 V DC.....	3
4.3.	Sensor inputs I a – I d.....	4
4.3.1.	LS 804.01.....	4
4.3.2.	LS 804.02.....	5
4.4.	Switching inputs IN1 to IN16.....	7
4.5.	Analogue outputs Vout and Iout.....	8
4.6.	Output relays and error relays K1 to K6 and Error1 and Error2.....	8
4.7.	Digital interfaces LAN, CAN and RS485/232 .....	8
4.7.1	Pin assignment / CAN interface .....	9
4.7.2	Pin assignment / RS485 interface / optional RS232 interface .....	9
<b>5.</b>	<b>Operation and display LS 804</b> .....	<b>10</b>
5.1.	Functions of keys.....	10
5.1.1.	Function keys.....	10
5.1.2.	Cursor keys.....	10
5.2.	LED indicators .....	11
5.2.1.	LEDs "SP1" and "SP2".....	11
5.2.2.	LED "Error" and error displays .....	12
5.3.	Matrix display - 4 x 20 characters .....	13
5.3.1.	Operating display / sensor signals a to d and switching contacts .....	13
5.3.2.	Operating display / network for browser accessing.....	14
5.3.3.	Operating display for load spectrum recorders .....	15
5.4.	Configuration via keypad .....	16
5.4.1.	Limits .....	16
5.4.2.	Adjustment.....	17
<b>6.</b>	<b>Configuration via web browser</b> .....	<b>18</b>
6.1.	Setting the IP address on the PC for use with a directly connected device .....	18
6.2.	Status (information) .....	20
6.3.	Settings (scaling, interfaces, password).....	21
6.4.	Adjustment (load calibration) .....	24
6.4.1.	Adjustment status.....	26
6.5.	Limits (K1 to K6).....	27
6.6.	Load spectrum recorders (LSR).....	29
6.7.	Configuration / Config .....	30
<b>7.</b>	<b>Maintenance / Error messages</b> .....	<b>31</b>
7.1.	Status of relays K1 to K6 .....	31
7.2.	Status of relays Error1 and Error2 .....	32
<b>8.</b>	<b>Instructions in the event of failure</b> .....	<b>33</b>
8.1.	Error overview .....	33
8.1.1.	Error overview / Sensor errors.....	33
8.1.2.	Error overview: hardware failure / adjustment errors .....	33
8.2.	Sensor errors.....	34
8.3.	Adjustment errors .....	34
8.4.	Communication errors / Logic units L1/L2.....	35
<b>9.</b>	<b>Technical data</b> .....	<b>36</b>
<b>10.</b>	<b>Project planning assistance</b> .....	<b>37</b>
<b>11.</b>	<b>EC declaration of conformity</b> .....	<b>38</b>



## 1. General description

The "LS 804 Load Switch" is a configurable switching device.

**Based on DIN ISO 13849, the design and architecture of the LS 804 load switch unite to bring about a high level of safety integrity. The appliance meets PerformanceLevel PL c.**

Up to a total of four sensors can be linked up to the device. The LS 804.01 is capable of processing sensors with a strain-gauge signal in mV/V, whereas the LS 804.02 processes sensors with a standard signal of 4-20 mA. Sensors processing a standard signal of 4-20 mA can be fed from the LS 804 applying 24 V DC.

The mode of operation on the device is set by configuration via a web browser in addition to individual setting and adjustment on the keypad. Depending on the number and type of the connected load sensors, individual, cumulative, differential and partial loads can be monitored.

Outputting of the freely parameterisable load shut-off points takes place via six relays ("K1" to "K6") with N/O contacts. Allocation of the relays to the load signals is freely configurable. In addition, the device incorporates two error relay outputs "Error1" and "Error2". These error relays are not freely programmable and generate a "0" status in the event of a system error occurring. The use of force-guided relays on the SLS 801 serves to ensure maximum system safety.

Two analogue outputs and two digital interfaces are provided for further application of the load signals on overriding systems.

## 2. Functional description



**CAUTION!** Any operating processes or adjustments performed on the keypad of the LS 804 via the web browser as well as changes made to the limit-set function by means of switching inputs IN1 to IN8 will render the switching function inoperative for the duration of this work and the resetting phase as well as for a few seconds afterwards.

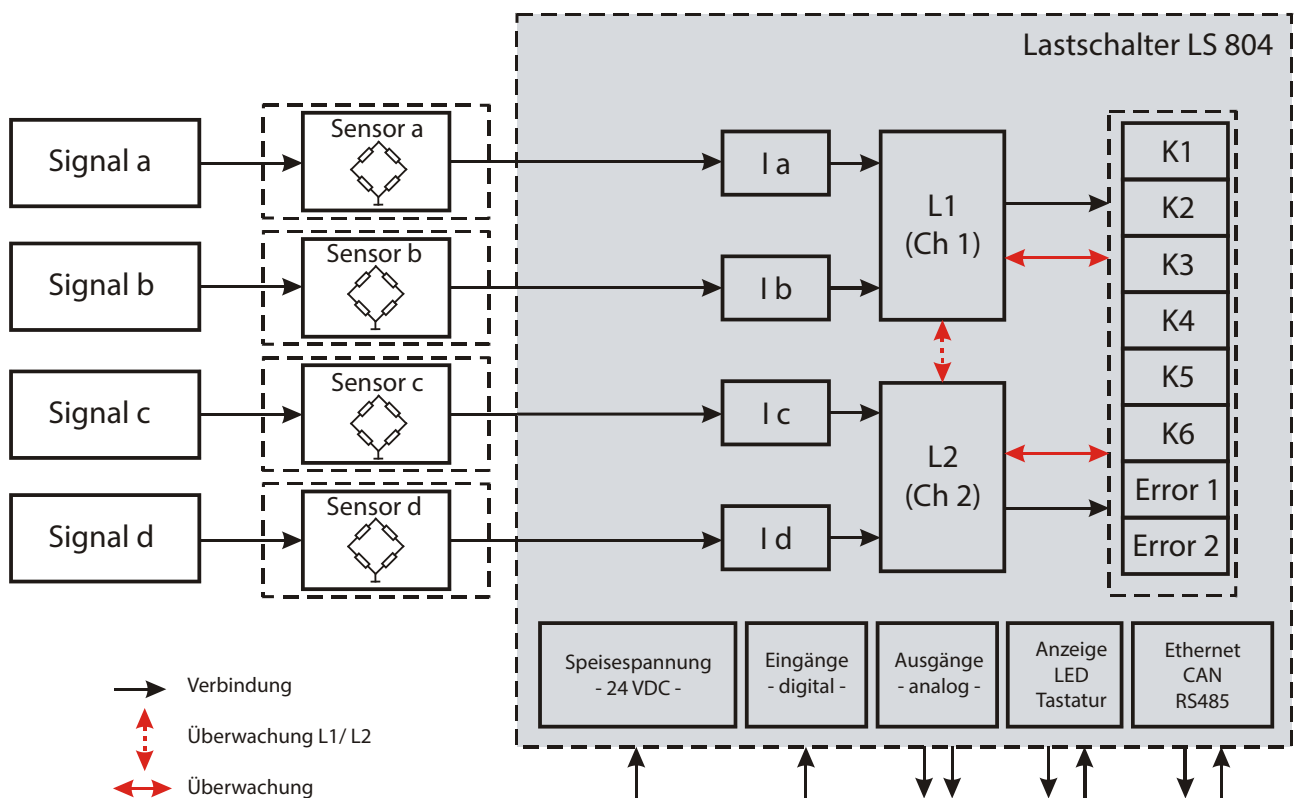

Figure 1 – Block diagram LS 804

Monitoring not only takes place of output relays "K1" to "K6" and error relays "Error1" and "Error2", but also of the load sensors with respect to cable rupture and short-circuiting. In the event of system errors occurring, the error relays will switch off. A sensor error on any input does not automatically lead to loss of function on the overall system. As a result of this functionality feature, a high level of safety is attained along with maximum possible availability.

The LS804 is designed with several peripheral interfaces.

- The two analogue outputs 0-10 V / 4-20 mA for sensors a to d or selected total formation.
- Connection: LAN (RJ-45)
- Connection X1: CAN
- Connection X2: RS485 / optional RS232

### 3. Dimensions

Dimensions: 102 mm x 105 mm x 205 mm / 1 kg

Weight: Approx. 1kg

Fastening on mounting rail TS35

Connection	Voltage supply	1.5 mm <sup>2</sup> screw terminals
	Switching outputs (relays)	1.5 mm <sup>2</sup> screw terminals
	Analogue outputs	1.0 mm <sup>2</sup> screw terminals
	Switching inputs	1.0 mm <sup>2</sup> screw terminals

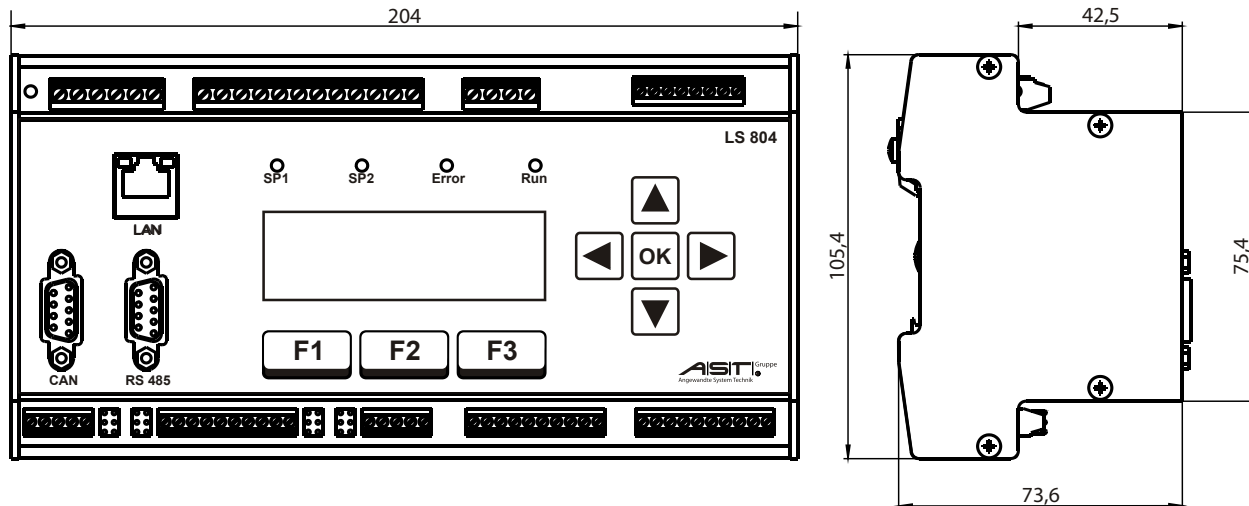

Figure 2- Dimensions LS 804

## 4. Electrical connection

### 4.1. Connection diagram

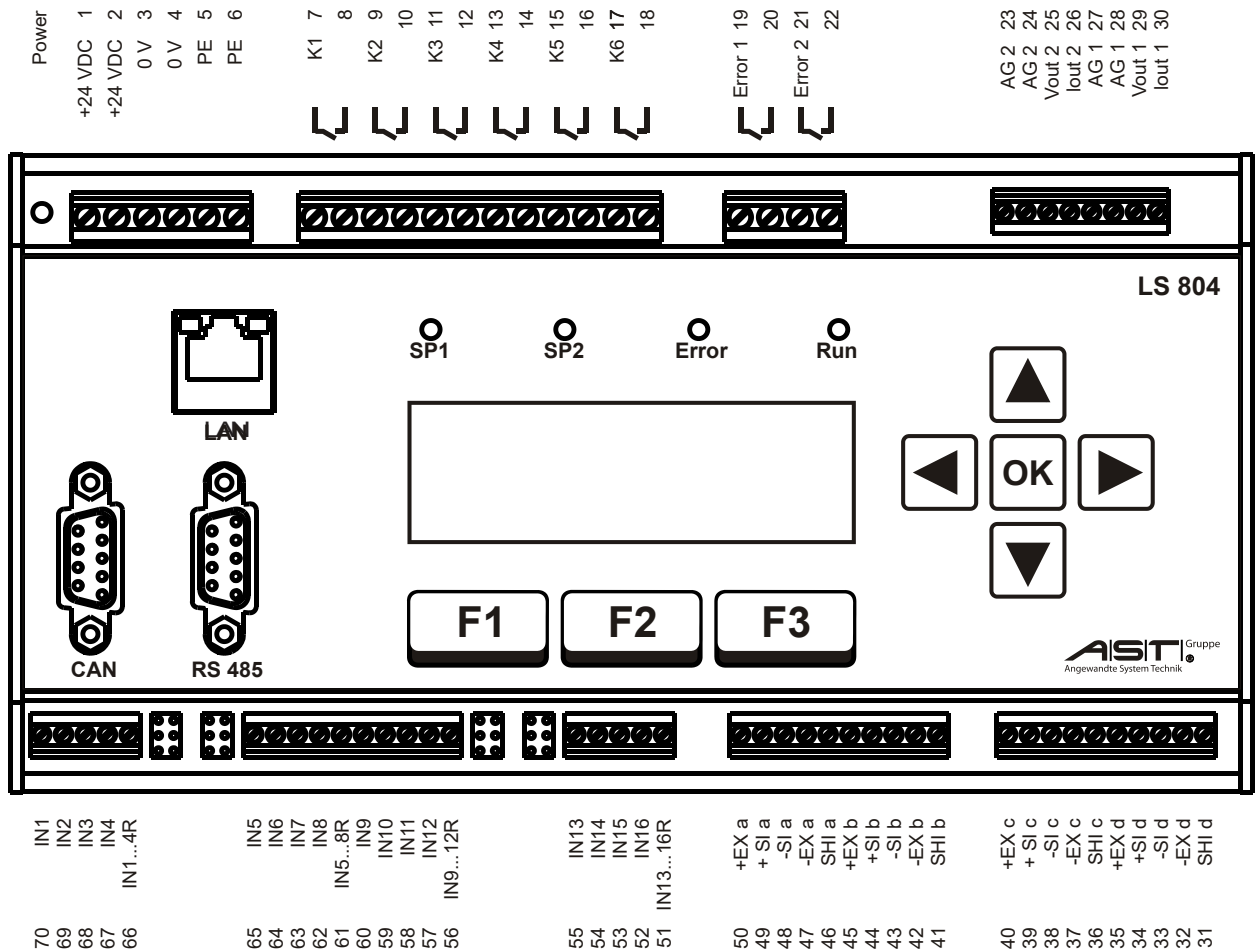
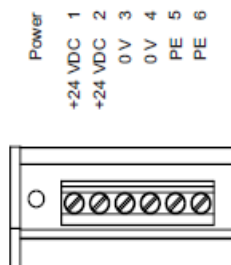

Figure 3 – Position and designation of connections

### 4.2. Voltage supply 24 V DC

The operating voltage is 18-36 V DC, this being based on a maximum power consumption of 15 VA. Operational readiness is indicated by means of an LED next to the 24 V AC connections. Conductors of up to 1.5 mm<sup>2</sup> can be connected up to terminal blocks 1 to 6.



After the operating voltage has been applied, the green LED “Power” indicator will light up next to terminal 1 as well as the “Run” LED.

### 4.3. Sensor inputs I a – I d

A total of four sensor connections are available.  
 Conductors of up to 1.0 mm<sup>2</sup> can be connected up to terminal blocks 31 to 50.

#### 4.3.1. LS 804.01

The LS 804.01 is designed for DMS sensors with a signal output range extending from -5mV/V to +5mV/V. The bridge resistors may be from 350 Ω ... 1000 Ω.  
 Input stages "I 1a" and "I 1b" serve to feed the DMS sensors with 5 V, input stages "I c" und "I d" supplying the DMS sensors with 3.3V.

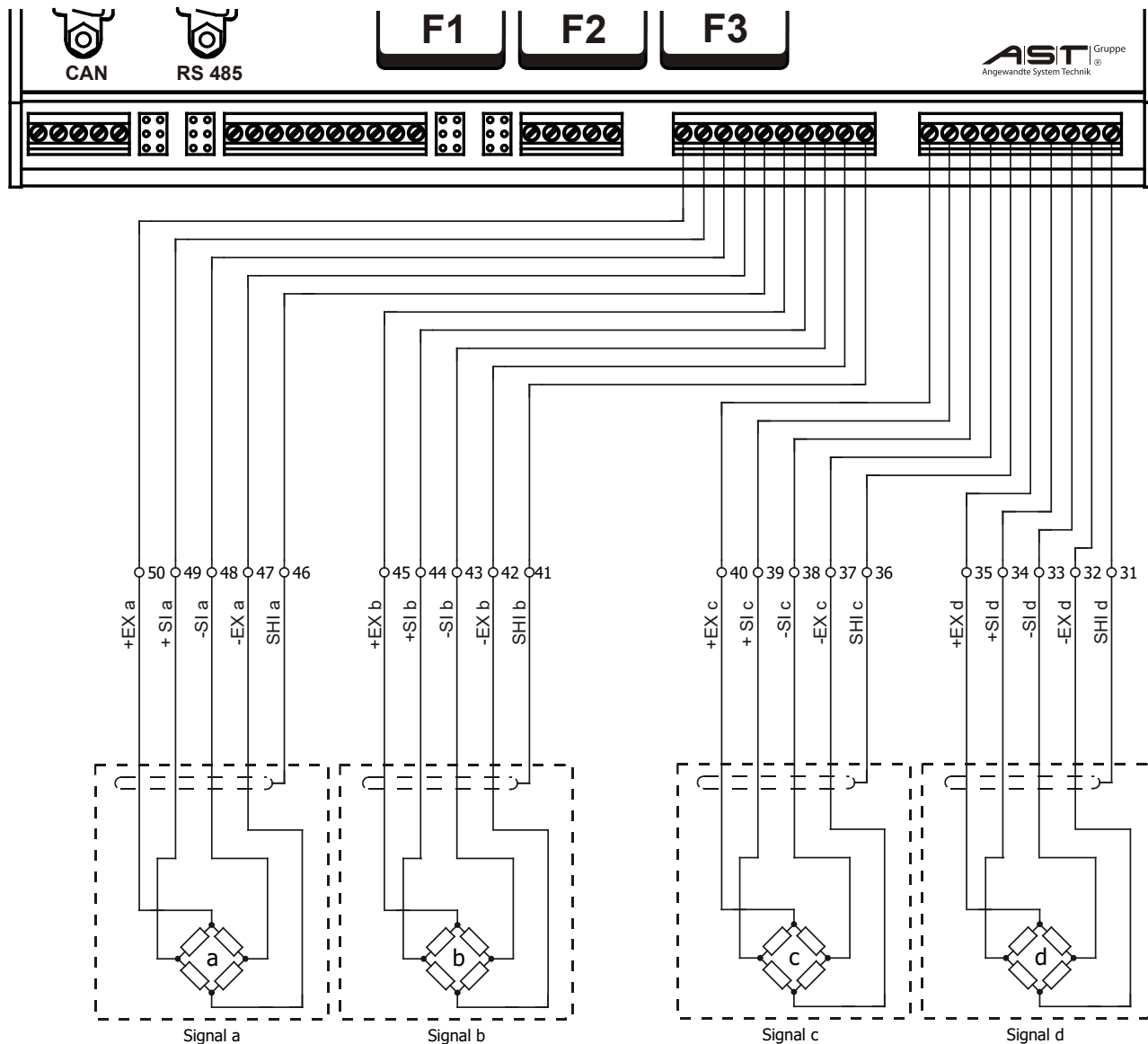

Figure 4– Sensor inputs I a – I d (LS 804.01)

### 4.3.2. LS 804.02

The LS 804.02 is designed for DMS sensors having an integrated or external DMS amplifier with a standard signal output 4-20mA.

The LS 804.02 feeds the amplifiers with 24V DC, max. 25 mA. The input signal range without error message extends from 1.5 mA to 24 mA.



**Note:** The "0V" connections of the respective sensors are bridged internally. If sensors with three conductors – "UB", "OUT" and "0V" – are available, connections 32, 37, 42 und 47 must be left free.

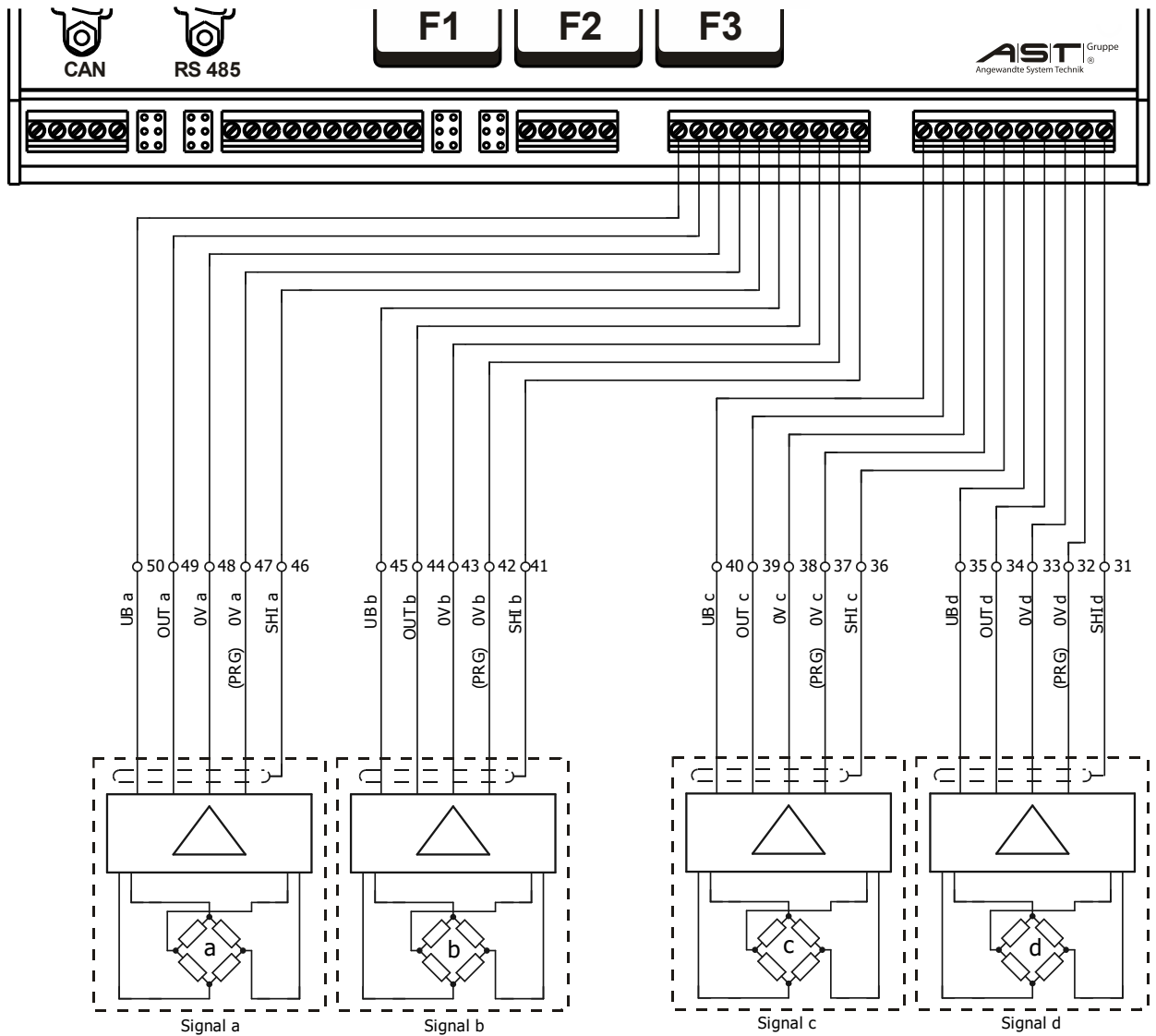

Figure 5 – Sensor inputs I a – I d (LS.804.02)

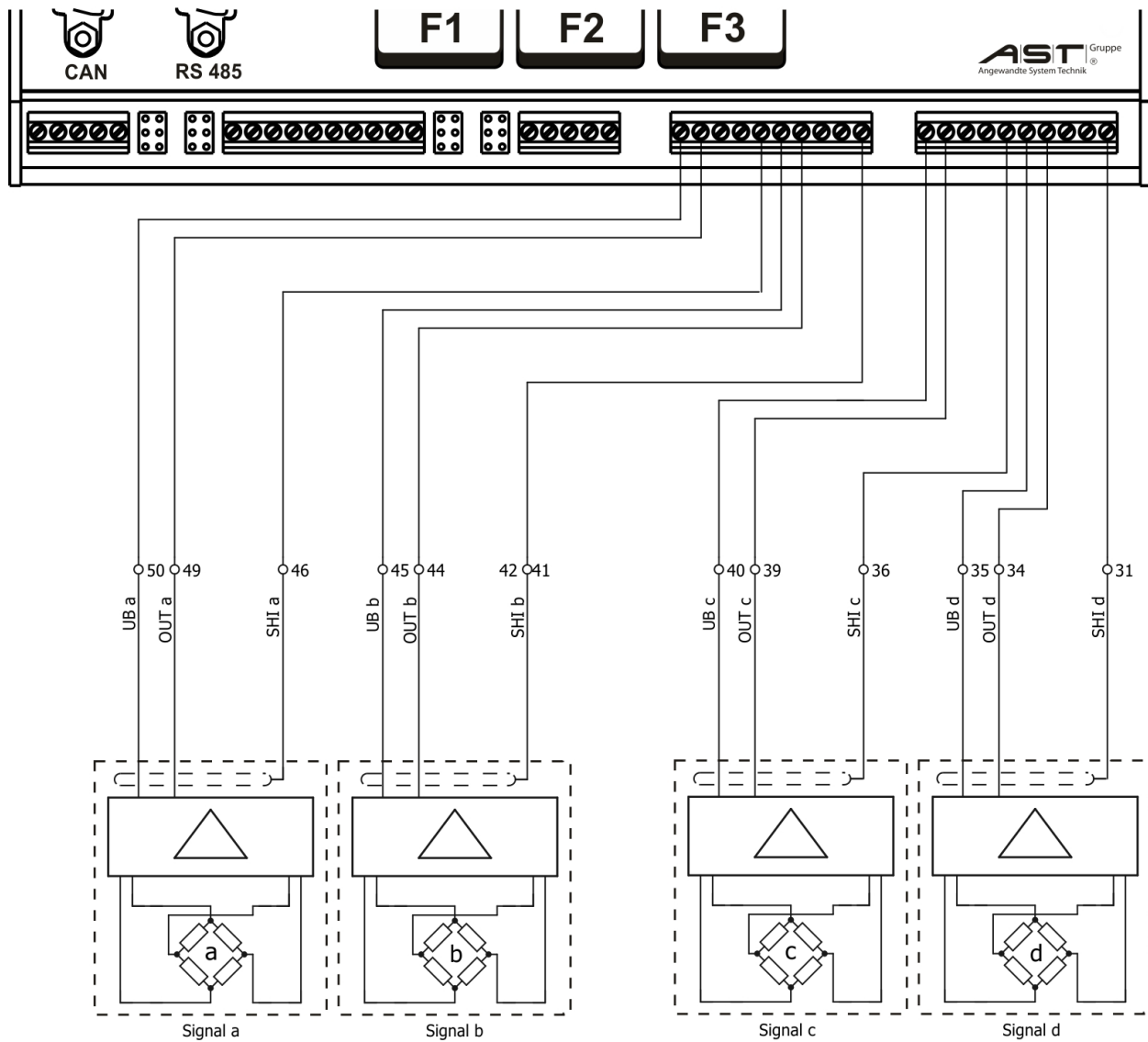

Figure 6 - Sensor inputs I a – I d (LS.804.02) - 2-wire connection

### 4.4. Switching inputs IN1 to IN16

Sixteen optocoupler inputs are arranged in four groups each group being made up of four inputs. Limit sets can be accessed to by means of inputs IN1 to IN8.

A static signal on the relevant input provides access to the corresponding limit set: Via IN1, set "1" is defined as the current set. If no signal is present, the LS 804 will operate with the limit set last displayed in Chapter 6.5 Limits (K1 to K6). If, by accident, more than one input is occupied by a signal, the LS 804 will utilise that input having the lowest number.

For the load spectrum recorder, inputs IN13 and IN16 are employed for switching the "Raise/Lower" signals (signals a to d). A signal applied to input IN12 generates the RESET function on the device in the event of an error occurring; also refer to Chapter 7 Maintenance / Error messages.

Static signal on	Reaction on LS 804
IN1	Accessing to limit set 1
IN2	Accessing to limit set 2
IN3	Accessing to limit set 3
IN4	Accessing to limit set 4
IN5	Accessing to limit set 5
IN6	Accessing to limit set 6
IN7	Accessing to limit set 7
IN8	Accessing to limit set 8
IN9	((unoccupied))
IN10	((unoccupied))
IN11	((unoccupied))
IN12	RESET function in the event of error (FATAL ERROR); also refer to Chapter on LED "Error".
IN13	Start up / Load spectrum recorders / Sensor a (signal for Raise/Lower)
IN14	Start up / Load spectrum recorders / Sensor b (signal for Raise/Lower)
IN15	Start up / Load spectrum recorders / Sensor c (signal for Raise/Lower)
IN16	Start up / Load spectrum recorders / Sensor d (signal for Raise/Lower)

Table 1 – Inputs

Return of the keying pulse "direct" or "+24 V DC" or "0 V" is set by means of jumpers INx...xR. Conductors of up to 1.0 mm<sup>2</sup> can be connected up to terminal blocks 51 to 70.

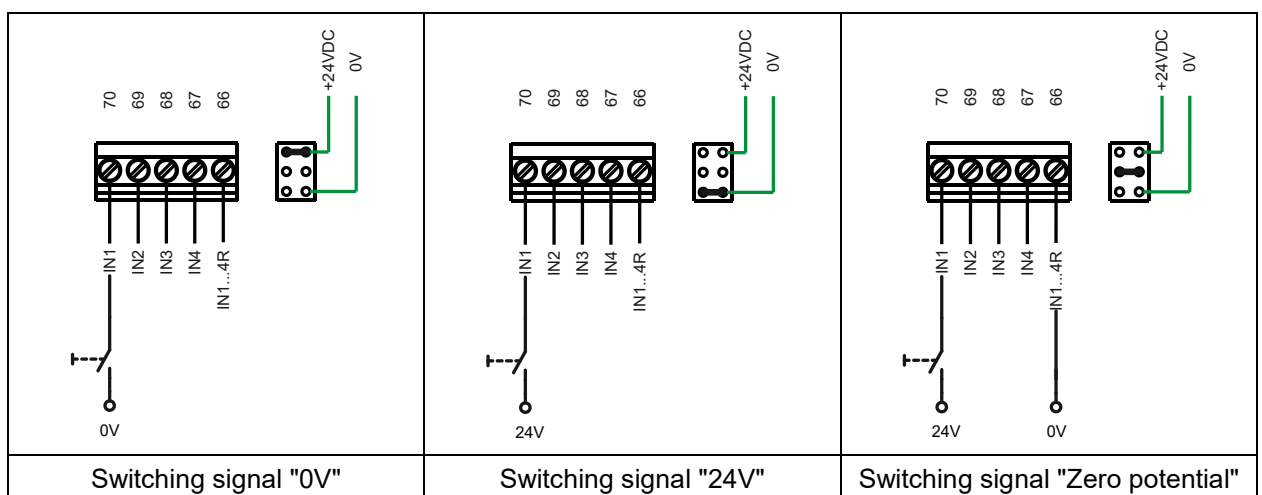

Figure 7 Examples illustrating return of keying pulse via jumpers (0V, 24V, zero potential)



**Note:** The jumper settings in Fig. 6 apply to all groups IN1...IN4 / IN5...IN8 / IN9...IN12 / IN13...IN16.

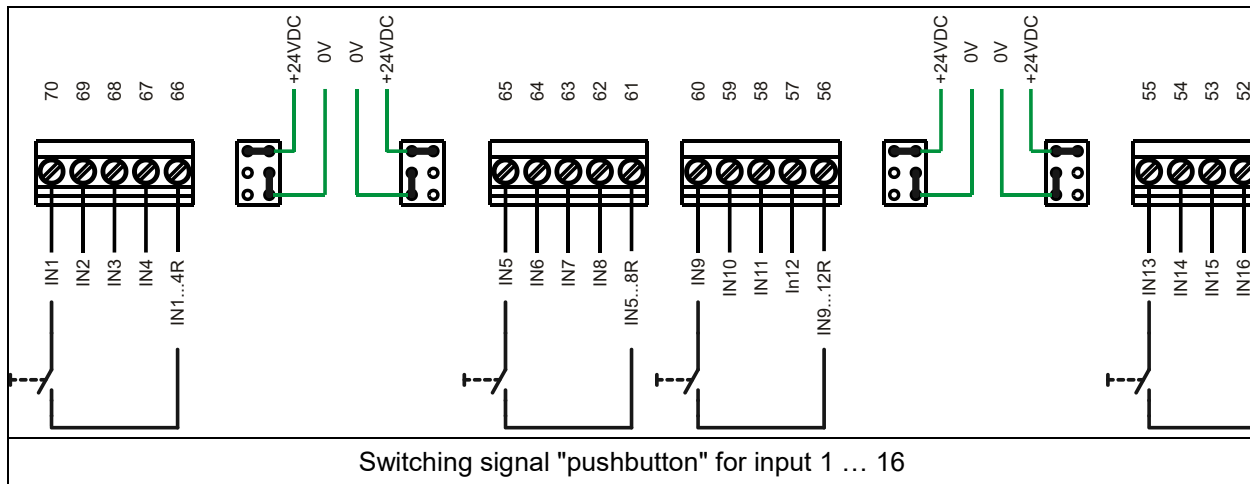

Figure 8 - Examples illustrating return of keying pulse via jumpers (pushbutton)

#### 4.5. Analogue outputs $V_{out}$ and $I_{out}$

The LS 804 features two analogue outputs AnalogOut1 and AnalogOut2, both of which are capable of being configured as voltage or current outputs ( $V_{out1}$  /  $I_{out1}$  or  $V_{out2}$  /  $I_{out2}$ ) – 0-10 V or 4-20 mA. The analogue output stages can be freely assigned to the input signals and their respective linkages, e.g. selected total formation (also refer to Chapter 6.3 Settings (scaling, interfaces, password)).

The maximum load of the current outputs may be 500  $\Omega$ ; the minimum load resistance for the voltage outputs must be 1 k $\Omega$ . Conductors of up to 1.0 mm<sup>2</sup> can be connected up to the terminal blocks.

#### 4.6. Output relays and error relays K1 to K6 and Error1 and Error2

The LS 804 is equipped with a total of eight switching outputs.

Six output relays – K1 to K6 – are freely adjustable within the scope of different applications with respect to input signals and their respective linkages (also refer to Chapter 6.5 Limits (K1 to K6)).

No access is provided to the two error relays Error1 and Error2. These are only triggered in the event of system errors occurring on the facility, sensor errors included.

The switching relays are force-actuated working contacts; their switching status can be indicated on the display.

The maximum switching capacity (DIN EN 60947-4-1 / EN 60947-4-1) is as follows:

AC1: 250V/6A, AC15: 230V/3A, DC1: 24V/6A, DC13: 24V/5A/0,1Hz, UL 508: B300 / R300.

Conductors of up to 1.5 mm<sup>2</sup> can be connected up to terminal blocks 7 to 22.

#### 4.7. Digital interfaces LAN, CAN and RS485/232

On the basic version of the LS 804 provision is made for three interfaces for data exchange or data transmission.

<b>LAN (RJ-45):</b>	Parameterisation of LS 804 via a browser.
<b>X1 (9-Pin-SUB-D):</b>	CAN interface.
<b>X2 (9-Pin-SUB-D):</b>	RS485 interface / optional RS232 interface.
	Cyclical output of measured values as ASCII string.

#### 4.7.1 Pin assignment / CAN interface

PIN	Function
1	(( unoccupied ))
2	(( unoccupied ))
3	CAN-L
4	CAN-GND
5	(( unoccupied ))
6	(( unoccupied ))
7	CAN-H
8	(( unoccupied ))
9	(( unoccupied ))

Table 2– X1 – Pin assignment / CAN interface

#### 4.7.2 Pin assignment / RS485 interface / optional RS232 interface

PIN	Function
1	(( unoccupied ))
2	(( unoccupied ))
3	485-B
4	(( unoccupied ))
5	485-GND
6	(( unoccupied ))
7	(( unoccupied ))
8	485-A
9	(( unoccupied ))

Table 3 – X2 – Pin assignment / RS485 interface

PIN	Function
1	(( unoccupied ))
2	232-TX
3	232-RX
4	(( unoccupied ))
5	232-GND
6	(( unoccupied ))
7	(( unoccupied ))
8	(( unoccupied ))
9	(( unoccupied ))

Table 4 – X2 – Pin assignment / optional RS232 interface

## 5. Operation and display LS 804

### 5.1. Functions of keys

#### 5.1.1. Function keys



The LS 804 device is set to the operating or programming status by means of function keys F1, F2 and F3.



**Note:** The functions of the respective keys F1 to F3 are indicated in the bottom line of the display matrix.

#### 5.1.2. Cursor keys



Further displays and operations take place by actuating the cursor keys.

Simultaneous pressing of keys:

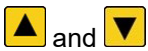

Information on network addresses (also refer to Chapter 5.3.2 – Operating display / network for browser accessing).

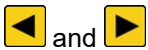

Adjustments menu for sensors and switching points (also refer to Chapter 5.4– Configuration via keypad).

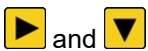

Operating display / Service life (also refer to Chapter 5.3.3– Operating display for load spectrum recorders).



**Note:** The cursor keys are only pressed simultaneously in the operating display for sensor signals (also refer to Chapter 5.3.1– Operating display / sensor signals a to d and switching contacts)).



Return to operating display / Sensor signals takes place according to the information indicated in the display.

## 5.2. LED indicators

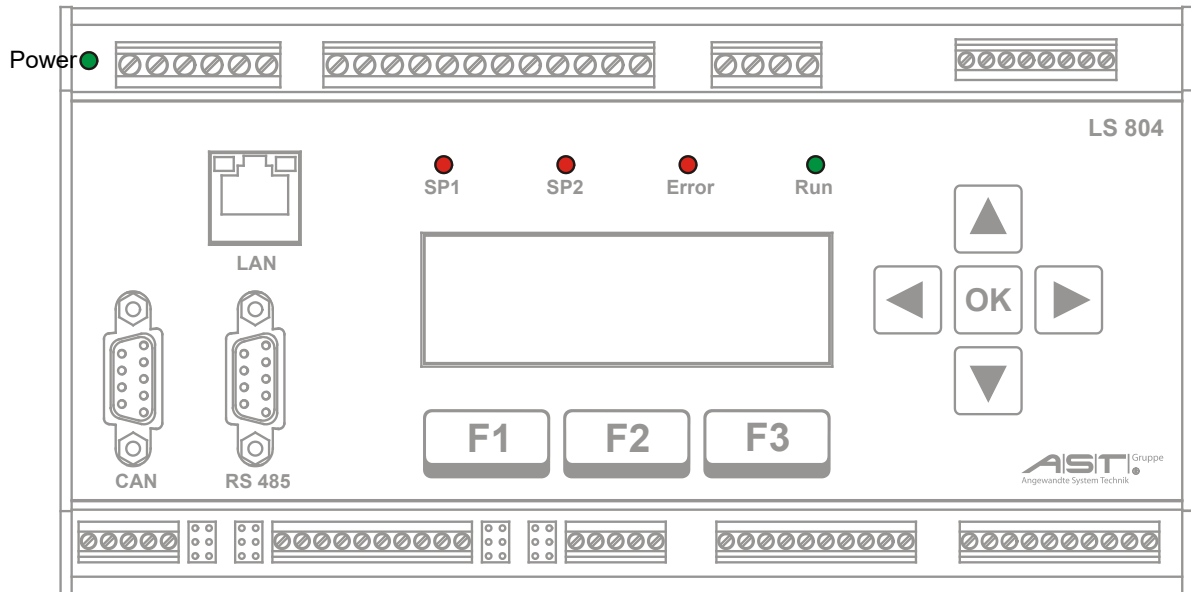

Figure 9– Position of LEDs

**Power:** 24 V DC supply voltage  
**Run:** LS 804 ready for operation



**Caution!** The LS 804 cannot be returned to the operating status (LED **Run** lights **green**) until the causes of failure have been eliminated and the device has been restarted by means of the **Reset** key, or input IN12.

**SP1/SP2** signalises at least one open contact "K1" to "K6" in each case.  
**Error** System error: At least one error relay "**Error1**" or "**Error2**" is open.

### 5.2.1. LEDs "SP1" and "SP2"

The LEDs "SP1" and "SP2" signalise that at least one contact "K1" to "K6" is open. These correspond to the settings specified in Chapter 6.5 Limits (K1 to K6) and can be queried by means of the operator actions specified in Chapter 5.3.1 Operating display / sensor signals a to d and switching contacts.

LED SP1: This references to sensor a to d when K1, K3, K4 and K5 trigger.

LED SP2: This references to sensor a to d when K1, K3, K4 and K6 trigger.



**Note:** The LEDs SP1 or SP2 will send a signal if any exceeding or falling-below of the switching thresholds has been detected (refer to Chapter 6.5 Limits (K1 to K6)).

### 5.2.2. LED "Error" and error displays



LED Error indicates a system error. At the same time an error message will appear in the display according to the following example:

```
FATAL - ERROR !
Ch 1 : SF : 0 D / HW : 0 9
Ch 2 : SF : 2 D / HW : 0 0
IP      F l a g s   R e s e t
```

Figure 10 – Error display

Pressing the  key facilitates switching between L1/L2 and the measured-value display.

Pressing key  **Flags** makes it possible to display selected error flags.

Actuating keys  or  facilitates swapping between the display of the SF flags and HW flags (hardware flags).



In the HW-flag display mode additional displaying of the flag values is possible indicating voltage supply errors/sensor errors (V-Exc-Flags 1/2).

```
SF - F l a g s
a : 0   b : 0   c : 0   d : 0
Exit
```

Figure 11 – SF flags

```
HW - F l a g s
a : 1   b : 0   c : 0   d : 0
V - E x c : 1
V - E x c           E x i t
```

Figure 12 – HW flags

Pressing  **V-Exc** and the keys  or  makes it possible to display flags indicating voltage supply errors (V-Exec-Flags 1) as well as individual sensor errors (V-Exc-Flags 2).

```
V - E x c - F l a g s 1
1 2 V : 0   5 V E / V : 0
3 . 3 V E : 0   3 . 3 V V : 0
Exit
```

Figure 13 – Flags indicating voltage supply errors (V-Exc-Flags 1)

```
V - E x c - F l a g s 2
S e n s a : 0   S e n s b : 0
S e n s c : 0   S e n s d : 0
Exit
```

Figure 14 – Flags indicating sensor errors (V-Exc-Flags 2)

Key to the different flags:

- 12V: Voltage supply/relay
- 5V E/V: Voltage supply/sensor supply voltage / Channel 1 (L1/Ch1)
- 3.3V E Sensor supply voltage / Channel 2 (L2/Ch2)
- 3.3V A Supply voltage / Channel 2 (L2/Ch2)
- Sens a: Sensor a (calibration/signal out of specification or wire breakage)
- Sens b: Sensor b (calibration/signal out of specification or wire breakage)
- Sens c: Sensor c (calibration/signal out of specification or wire breakage)
- Sens d: Sensor d (calibration/signal out of specification or wire breakage)



Further information on error messages/causes and their elimination will be found described in Chapter 8 Instructions in the event of failure occurring.

### 5.3. Matrix display - 4 x 20 characters

The four-line matrix display serves to indicate operating statuses and signals as well as acting as a display when configuring the LS 804.

Die 4-zeilige Matrixanzeige dient sowohl der Anzeige von Betriebszuständen und Signalen als auch der Anzeige bei der Konfiguration des LS 804.

#### 5.3.1. Operating display / sensor signals a to d and switching contacts

Following application of the operating voltage and the connection of operable sensors, sensor signals a and b will be displayed.

R u n	-	C h	1	
a :	3	.	2	t *
b :	1	.	7	t
S u M		c / d		R e l

Figure 15 – Operating display / sensor signals

Using cursor keys or facilitates switching back and forth to and from the % display.

Pressing key **c/d** the display will switch to the values of the sensors c and d.



\* Load spectrum recorder is active! (also refer to 5.3.3 - Operating display for load spectrum recorders).

Actuating key **Rel** serves to display the status of the output relays **K1 to K6**. (Example: “K1: 0” – K1 closed; “K5: 1” – K5 open) and the error relays Error1 and Error2.

K 1 : 0	K 4 : 0	E 1 : 0
K 2 : 0	K 5 : 1	E 2 : 0
K 3 : 0	K 6 : 0	
		E x i t

Figure 16 – Operating display / Switching contacts

### 5.3.2. Operating display / network for browser accessing

Information on the network addresses and other details can be obtained from the operating display of the sensor signals by pressing keys  and  simultaneously.

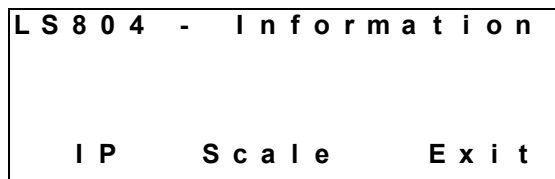



Figure 17 - LS804 – Information

Actuating key  **IP** serves to display network information including the IP address of the device, by means of which it is possible to access to the LS 804 via a browser.

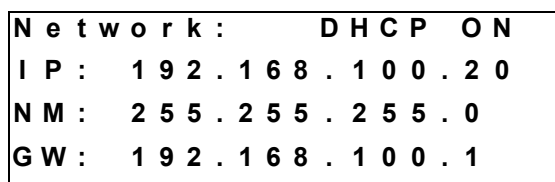
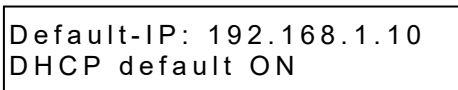



Figure 18 – Network information





The IP address can be assigned automatically from a linked-up DHCP server if the value "DHCP = On" has been set (also refer to Chapter 6.3. Settings (scaling, interfaces, password)). If no DHCP server is found in the network, the IP address will have been set to the above value.

Default login data (if default): Login:**admin**) / Password: **admin** (refer to Chapter 6.3).

Pressing the  key returns the user to menu "LS804 – Information".

Key  **Scale** indicates the 100% values (nominal characteristics) of sensors a to d (also refer to Chapter 6.3 Settings (scaling, interfaces, password)).

Actuating  or  brings about a display change of sensors a/b and c/d.

In addition the LS 804 variant (mV / mA) will be displayed as well as the current limit set.

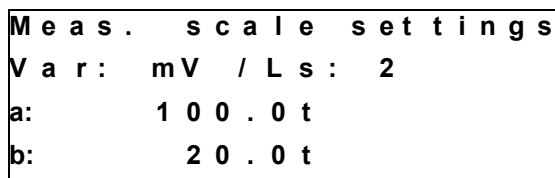



Figure 19 – Scaled values for signal a and signal b

Actuating the  button returns the user to menu " LS804 – Information".

### 5.3.3. Operating display for load spectrum recorders

Load spectrum recorders (LSR) are provided for displaying the service life of the individual sensors a to d, computed in accordance with FEM Directive 9.755.

For this purpose, a signal is evaluated second-by-second, proportional to the load 0...100% of the relevant hoist unit when this is operated and saved in a totalizing memory.



The contents of this totalizing memory constitute the actual useful life S. This can be displayed both in hours as actual useful life S and as a percentage % as consumed useful life  $V = S/D$ .



**Note:** All inputting of the theoretical useful life D and the starting value for actual useful life S is carried out employing a web browser (Chapter 6.6 Load spectrum recorders (LSR)).



**Note:** The service life is computed for each sensor individually and cannot be made up of several input signals.

Pressing  and  switches the system to the operation display containing the service-life indicator (also refer to Chapter 6.6 Load spectrum recorders (LSR)).



```

L S 8 0 4   -   L S R
S e n s o r   a   :   -
S e n s o r   b   :   R U N
S e n s   a   S e n s   b   E x i t
    
```

Figure 20 Operation display – Load spectrum recorders

Fig. 19 indicates that the totalized service life in respect of sensor b. The given example indicates an operating signal arriving from hoist unit b). No operating signal is shown to be coming from sensor a (e.g. hoist unit a).

Exiting of the display is carried out by pressing the  key.

Actuating  or  brings about a display change of sensors a/b and c/d.

In the given example pressing key  **Sens a** makes it possible to access to information on the service life in respect of sensor a (hoist unit a).

```

L S R   -   S e n s o r   a
D [ h ] :   1 2 0 0
S [ h ] :     1 2 3
V [ % ] :     1 0 . 2
    
```

Figure 21 - Service-life display – Sensor a

Exiting of the display is carried out by pressing the  key.

## 5.4. Configuration via keypad



**Note:** Where configurations are triggered via the web browser, the respective setting options are blocked by LCD / keypad so as to prevent operating errors.

Pressing and triggers change to the Adjustments Menu governing the sensor signals.

In menu LS804 – Functions it is possible to carry out readjustments to the sensor signals a to d in respect of zero load (0%) and full load (100%) as well as changes to the switching points. A precondition for this is that the configuration has previously been carried out via the web browser.

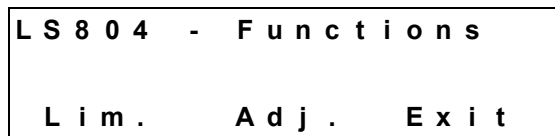

Figure 22– Function menu



**Lim.:** Menu for setting the limits on the current limit set (refer to 5.4.1 Limits)



**Adj.:** Adjustments Menu for setting the zero load and final value (refer to 5.4.2 Adjustment).

### 5.4.1. Limits

In the "Limit" menu, the display on the LS 804 only shows the values of the current limit set. This will have previously been accessed to by means of an input signal or determined in accordance with Chapter 6.5 Limits (K1 to K6) with the "Limit set" function. On the LS 804 it is possible to deposit up to 8 limit sets.

Depressing or serves to trigger selection of the limit.

Actuating or brings about a change in the values of the relevant limit.



must be pressed to complete the changes to the display!

If this is not done, it will not be possible to access to information on other switching points using keys or .

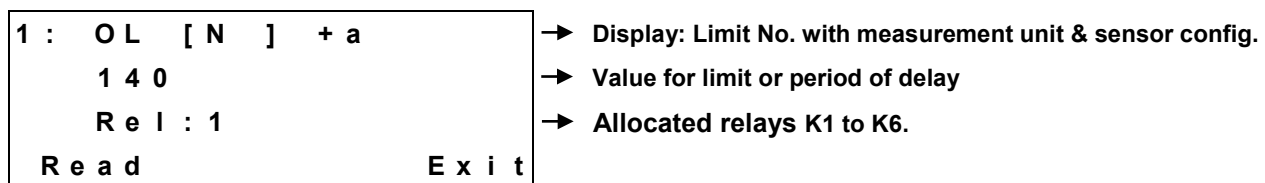

Figure 23 – Display of switching point (where overloading occurs of 140% in respect of sensor a, relay 1 (K1) will be switched off with a time lag).

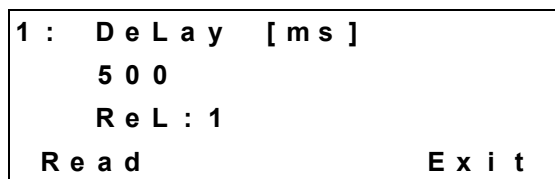

Figure 24 - Display of switching point (where a switching condition is met for signal a, relay 1 (K1) will be switched off if that switching condition is not met after 500 milliseconds).





**Note:** Allocation of the switching relays K1 to K6 can only be set via a web browser! (Refer to Chapter 6.5 Limits (K1 to K6)).

### 5.4.2. Adjustment

Sensors a to d can be accessed to in the Adjustments Menu.

The sensor signals a and b can be adjusted in accordance with the following illustration (Fig. 25):

Using cursor keys  or  facilitates switching back and forth to and from the display containing sensors c and d.

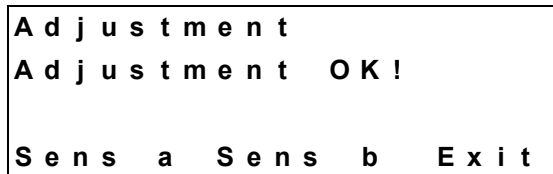

Figure 25– Adjustments menu for selecting sensor a or b

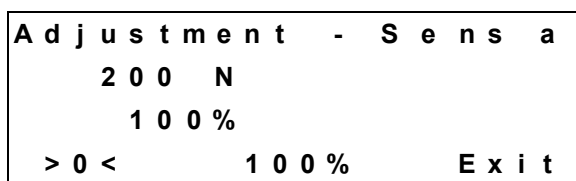







Figure 26– Adjustments menu for sensor a

 **>0<**: Adjustment of zero load **>0<**. A precondition is that the signal of sensor a is load-free.

 **100%**: Adjustment of full load **100%**. The signal of sensor a must generate a 100% load!



**Caution!** When actuating the keys  **>0<** and  **100%** the values are only set temporarily. The values are not saved until the Adjustments menu is quitted by pressing  **Exit!**

 **Exit**: Exiting of Adjustments menu and prompting to save adjustment "Save Adjustment?"

 **Adj.:** Repetition of adjustment process.

 **Yes:** Saving of readjusted temporary values.

 **No:** Exiting of menu without saving the adjusted temporary values.

The same process is carried out in respect of adjustments to sensors c and d.

## 6. Configuration via web browser

The configuration routine is accessed to via the browser by means of the IP address specified under Chapter 5.3.2 Operating display / network for browser accessing (Figure 18 – Network information).

The LS 804 load switch has been operably tested under the following browsers/operating systems:

- WindowsXP → Web-Browser Chrome, Firefox, Opera, Internet-Explorer
- Windows7/8/10 → Web-Browser Chrome, Firefox, Opera

### 6.1. Setting the IP address on the PC for use with a directly connected device

If the LS 804 is not connected via a network but directly to a PC, the following settings must be made.

The devices LS 804 use the 192.168.1.10 as default IP address.

#### Windows 7

1. Start -> Control Panel

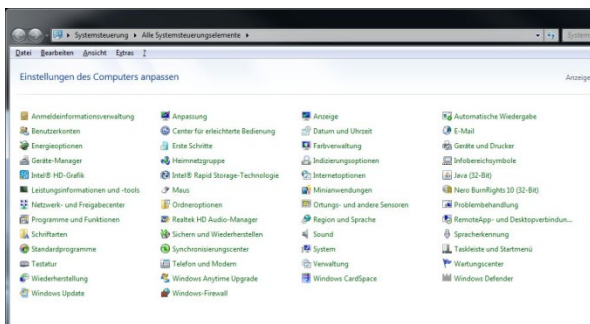

2. Network and Sharing Center

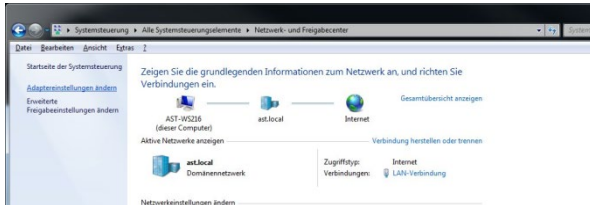

- 3 Left selection -> Changing Adapter Settings

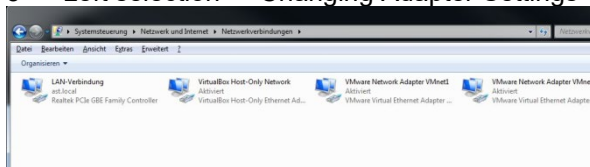

#### Windows 10

1. Start -> Settings -> Windows-Settings -> Network and Internet



2. Ethernet -> Changing Adapter Options

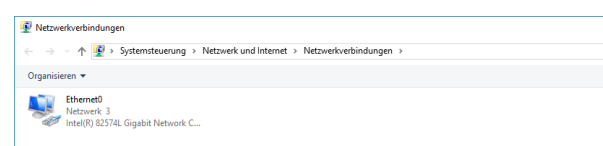

continue under point 4.

## 4 Right mouse button -> Properties (if network adapter is used)

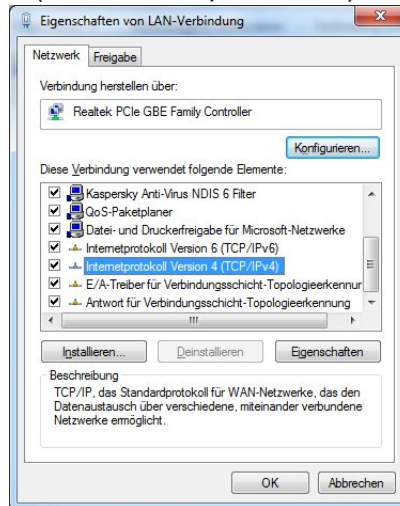

## 5 Internet Protocol Version 4 (TCP/IPv4) -> features

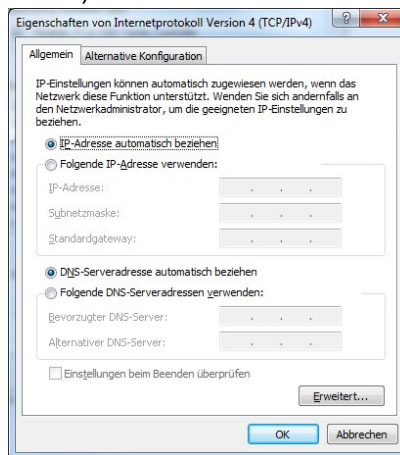

Entering a fixed IP address

In the controller, "Obtain IP address automatically" is set.

Please change to "Use the following IP address" and enter e.g. an IP address 192.168.1.11 and the net mask 255.255.255.0.

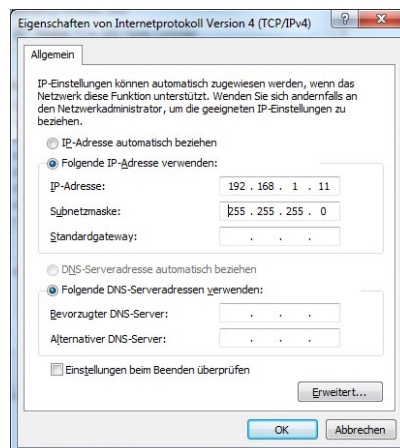

The settings for the default gateway and DNS server can remain empty. Exit with "OK".



**Note:** After changing the IP address, it may take a few minutes for the system to use it and connect to the device.

## 6.2. Status (information)

After the configuration routine has been accessed to via the browser, the following image will appear:

LS804 - Configuration

Gruppe  
Angewandte System Technik

[| Status](#) | [Settings](#) | [Adjustment](#) | [Limits](#) | [LSR](#) | [Config](#) |

Status

---

[Error status](#)

Comm. - Channel 1	Ok	/ SF=00	HW=00
Comm. - Channel 2	Ok	/ SF=00	HW=00

[Relais status](#)

Relais	RelOut=FF	RelIn=FF
--------	-----------	----------

[Network information](#)

MAC address	1E:30:6C:A2:01:01
IP address	192.168.200.56
Fixed IP address	169.254.1.1
Net mask	255.255.255.0

[Channel information](#)

	Run		
Sensor a	133 N	67 %	
Sensor b	132 N	66 %	
Sum a/b	266 N		
	Run		
Sensor c	200 N	50 %	
Sensor d	200 N	50 %	
Sum c/d	400 N		
Sum a-d	666 N		

[System information](#)

Device	LS804
Serial	2013_00001
Firmware	V1.0.1
Hardware	Rev. 2
Setup checksum	DCD2
Setup ID	11
RS232/RS485	1 / 0
CAN ID snd	528 (0x210)
CAN ID rcv	512 (0x200)
Input 1/2	00 / 00
Limit set	1
Channel 1 - HW	0801050D/mV
Channel 1 - SW	02010005
Channel 2 - HW	0401050D/mV
Channel 2 - SW	02010005

Copyright © 2013-2016 [A.S.T. Angewandte System Technik GmbH](#), All rights reserved.

Figure 27 – Status information (LS804.01)

The "Channel information" section contains the display for sensors a to d as well as the cumulative loads a/b, c/d and a-d along with additional system information.

In the event of an error occurring, the causes of failure can be determined by actuating the "Error Status" link (also refer to Chapter 7.2 Status of relays Error1 and Error2).

Actuating the "Relay status" link will display the status of the contacts K1 to K6 (also refer to Chapter 7.1 Status of relays K1 to K6).

### 6.3. Settings (scaling, interfaces, password)

By accessing to the “Settings” window it is possible to display and modify the current data. Any changes made to the settings are written into the device by pressing the **OK** button.

**LS804 - Configuration** **AST** Gruppe  
Angewandte System Technik

| [Status](#) | [Settings](#) | [Adjustment](#) | [Limits](#) | [LSR](#) | [Config](#) |

---

### Settings

*Measurement scale settings*

	Used	Final value (100%)	Decimal places	Unit
Sensor a	<input checked="" type="checkbox"/>	200	0	N
Sensor b	<input checked="" type="checkbox"/>	200		
Sensor c	<input checked="" type="checkbox"/>	200		
Sensor d	<input checked="" type="checkbox"/>	200		

---

*CAN settings (X1)*

CAN ID send (base)

CAN ID receive

CAN baudrate

Values out

Values out interval  [ms]

*RS485/RS232 settings (X2)*

Baud rate

Data bits

Parity

Stop bits

Values out

Values out interval  [s]

---

*Network settings*

Conf. IP address

Net mask

Gateway

DHCP

*Analogue out settings*

**Analog 1**

Aout1 - Type

Aout1 - Signal

**Analog 2**

Aout2 - Type

Aout2 - Signal

---

*Security settings (Login: admin)*

Authentication **Disabled**

Password

Password confirmation

Master password

Copyright © 2013-2018 A.S.T. Angewandte System Technik GmbH. All rights reserved.

Figure 28 – Settings, basic settings

## Measurement scale settings

Entry of 100% values in respect of sensors a to d. This might be for example the rated loads of hoist unit a and b. The values can only be entered as whole numbers. Any of the sensors can be disabled at will.



**Note:** Where changes are made to the individual sensors, the LS 804 will automatically switch over to the Adjustments Mode after the "OK" button has been pressed.

## Analogue out settings

Aout –Type: The analogue outputs can be configured either as voltage or current outputs.

Aout – Signal: The output signal refers to the 100% value of the selected sensors a to d.  
The following individual values are available for selection **a, b, c, d,  $\Sigma a+b$ ,  $\Sigma c+d$ , or  $\Sigma a-d$** .

## CAN settings (X1)

When setting the cyclical value output – "**Values out**" to "**ON**" or „**On - Meas.**“ – outputting of the following values takes place on the CAN interface together with the configured interval – "Values out interval".

Output-interval settings are possible from 50...5000 ms.

Two CAN telegrams with different CAN IDs are sent with the float values of sensors a and b or sensors c and d.

ID send (base):

DLC	B0	B1	B2	B3	B4	B5	B6	B7
8	<i>a_float</i>	<i>a_float</i>	<i>a_float</i>	<i>a_float</i>	<i>b_float</i>	<i>b_float</i>	<i>b_float</i>	<i>b_float</i>

ID send (base+1):

DLC	B0	B1	B2	B3	B4	B5	B6	B7
8	<i>c_float</i>	<i>c_float</i>	<i>c_float</i>	<i>c_float</i>	<i>d_float</i>	<i>d_float</i>	<i>d_float</i>	<i>d_float</i>

## RS485/RS232 settings (X2)

„**Values out**“:

"**On – Meas.**" – outputting takes place of the following formatted ASCII telegram on the serial interface cyclically with the configured interval – "Values out interval".

*"a:%s b:%s c:%s d:%s Sab:%s Scd:%s Sabcd:%s\r\n"*

In the configured scaling these values are transmitted with decimal places and unit of measurement.

"**On - LSR**", the values of the load collective counters are output cyclically as **float** values with the following telegram (36 bytes). Available as of FW-V1.0.7.1.

*STX – LEN – LKZa(S) – LKZa(V) – LKZb(S) – LKZb(V) – LKZc(S) – LKZc(V) – LKZd(S) – LKZd(V) – CSum – ETX*

STX (1 Byte): 2 / 0x02  
 LEN (1 Byte): 16 / 0x16  
 LKZx(Y) (32 Byte): 8x float-values  
 CSum (Byte): 1's complement of the 8 LKZ values  
 ETX (1 Byte): 3 / 0x03

„On - **DAxy**“ for a digital large digit display

On – DA55-4 for a digital large numeric display with 4 digits

On – DA55-5 for a digital large numeric display with 5 digits

On – DA55-6 for a digital large numeric display with 6 digits

The following individual values sensor are available for selection **a, b, c, d,  $\Sigma a+b$ ,  $\Sigma c+d$ , oder  $\Sigma a-d$ .**

„**Values out interval**“:

Output-interval settings are possible from 1...240 s (4 Min.).

### **Security settings**

Factory default *Security settings (Login admin)*, when set

Username/Login (not changeable)	<b>admin</b>
Password	<b>admin</b>
Master password	<b>1803</b>

An existing password is deleted by erasing the contents of fields *Password* and *Password confirmation* and then entering the *Master password*.

### 6.4. Adjustment (load calibration)

This is where adjustment of the LS 804 to the sensors essentially takes place. Accessing to the "Adjustment" window will display the current data on "Sensor characteristics".

**LS804 - Configuration** **AST** Gruppe  
Angewandte System Technik

| [Status](#) | [Settings](#) | [Adjustment](#) | [Limits](#) | [LSR](#) | [Config](#) |

**Adjustment**

---

*Note: Press the "Save" button to use the adjustment!*

[Adjustment status](#)

**Sensor characteristics**

**Input sensitivity**

Sensor a <input type="text" value="20.0"/> [mV/V] ( 200 t )	Sensor b <input type="text" value="20.0"/> [mV/V] ( 200 t )
Sensor c <input type="text" value="15.0"/> [mV/V] ( 200 t )	Sensor d <input type="text" value="30.0"/> [mV/V] ( 200 t )

**Load calibration**

**Real load**

Sensor a <input type="text" value="200"/> [t]	330 t	165 %
---	-------	-------

**Real load**

Sensor b <input type="text" value="200"/> [t]	28 t	14 %
---	------	------

**Real load**

Sensor c <input type="text" value="200"/> [t]	200 t	100 %	Adj. not saved!
---	-------	-------	-----------------

**Real load**

Sensor d <input type="text" value="200"/> [t]	-1011 t	-505 %	Adj. not OK!
---	---------	--------	--------------

Copyright © 2013-2016 A.S.T. Angewandte System Technik GmbH. All rights reserved.

Figure 29 – Adjustment, setting the LS 804 according to sensor characteristics (LS 804.01)

**Sensor characteristics**

**Input sensitivity**

Sensor a <input type="text" value="4.20"/> [mA]	Sensor b <input type="text" value="4.20"/> [mA]
Sensor c <input type="text" value="4.20"/> [mA]	Sensor d <input type="text" value="4.20"/> [mA]

Figure 30 – Adjustment, setting the LS 804 according to sensor characteristics (LS 804.02)





Button	
	Release of "Adjustment" feature for changes and calibrations. The header "Adjustment active" will appear.
	Saving of entered values for <i>sensor characteristics</i> .
	Saving of entered values – and calibrations where applicable – from the temporary memory buffer on the device.
	Exiting this menu without taking over the entered values; the current data will be retained.
	An adjusted characteristic is deleted and the factory default setting adopted. The appliance needs to be re-adjusted!

Table 5 – Buttons Adjustment

### **Sensor characteristics**

Indication of characteristics for sensors a to d at maximum anticipated load signal.

### **Load calibration**

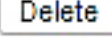
Calibration of sensors a to d takes place here.



**Note:** No functioning of the LS 804 will be possible unless the sensors (load calibration) are adjusted. Incorrect adjustment or no adjustment at all will unleash the following message: *Adj. not OK!*

Further information on adjustment status will be found under 6.4.1 Adjustment status !



**Caution!** Adjusted values (load calibration) will not be taken over by the LS 804 until the **SAVE** button is pressed! As long as the values have not been taken over the following message will appear: *"Adj. not saved!"*!

### **Adjustment status**

Refer to 6.4.1 Adjustment status.

### 6.4.1. Adjustment status

Via the „Adjustment status“ link it is possible to check whether all necessary steps have been performed and completed for adjustment.

LS804 - Configuration			
AST Gruppe Angewandte System Technik			
Adjustment status			
	Justage flags		
	NullP	EndP	Justage Done
Sensor a	1	1	1
Sensor b	1	1	1
Sensor c	1	1	1
Sensor d	1	1	1

Copyright © 2013-2016 A.S.T. Angewandte System Technik GmbH, All rights reserved.

Figure 31 – Adjustment status – Adjustment completed

LS804 - Configuration			
AST Gruppe Angewandte System Technik			
Adjustment status			
	Justage flags		
	NullP	EndP	Justage Done
Sensor a	1	1	1
Sensor b	0	0	0
Sensor c	1	1	1
Sensor d	0	0	0

Copyright © 2013-2016 A.S.T. Angewandte System Technik GmbH, All rights reserved.

Figure 32 – Adjustment status – Adjustment wrong

#### Meaning of various flags:

1 = OK / 0 = not OK

- NullP: Adjustment zero point Button > 0 <).
- EndP: Adjustment final point or adjustment with load (Button **Load**).
- Justage Done: Completion of adjustment (Button **Save**).

### 6.5. Limits (K1 to K6)

Accessing to the "Limit set" window will display the current settings in respect of switching points K1 to K6 for that particular limit set currently in use.

## LS804 - Configuration

| Status | | Settings | | Adjustment | | Limits | | LSR | | Config |

### Limits

---

*Limits - Signal handling*

**Note: Press the "Save" button to use the limits!**

---

*Definition of limits*

Limit set 1 ▾

Enable change with dig. Inputs

Limits 1...4												
a	b	c	d	Type	Value	Delay	Relais					
					[N ]	[ms]	K1	K2	K3	K4	K5	K6
<span style="border: 1px solid black; padding: 2px;">+a ▾</span>	<span style="border: 1px solid black; padding: 2px;">-- ▾</span>	<span style="border: 1px solid black; padding: 2px;">-- ▾</span>	<span style="border: 1px solid black; padding: 2px;">-- ▾</span>	<span style="border: 1px solid black; padding: 2px;">Ovl ▾</span>	<input style="width: 50px;" type="text" value="200"/>	<input style="width: 50px;" type="text" value="500"/>	<input checked="" type="checkbox"/>	<input type="checkbox"/>	<input type="checkbox"/>	<input type="checkbox"/>	<input type="checkbox"/>	<input type="checkbox"/>
<span style="border: 1px solid black; padding: 2px;">-- ▾</span>	<span style="border: 1px solid black; padding: 2px;">+b ▾</span>	<span style="border: 1px solid black; padding: 2px;">-- ▾</span>	<span style="border: 1px solid black; padding: 2px;">-- ▾</span>	<span style="border: 1px solid black; padding: 2px;">Ovl ▾</span>	<input style="width: 50px;" type="text" value="200"/>	<input style="width: 50px;" type="text" value="500"/>	<input type="checkbox"/>	<input checked="" type="checkbox"/>	<input type="checkbox"/>	<input type="checkbox"/>	<input type="checkbox"/>	<input type="checkbox"/>
<span style="border: 1px solid black; padding: 2px;">-- ▾</span>	<span style="border: 1px solid black; padding: 2px;">-- ▾</span>	<span style="border: 1px solid black; padding: 2px;">+c ▾</span>	<span style="border: 1px solid black; padding: 2px;">-- ▾</span>	<span style="border: 1px solid black; padding: 2px;">Ovl ▾</span>	<input style="width: 50px;" type="text" value="200"/>	<input style="width: 50px;" type="text" value="500"/>	<input type="checkbox"/>	<input type="checkbox"/>	<input checked="" type="checkbox"/>	<input type="checkbox"/>	<input type="checkbox"/>	<input type="checkbox"/>
<span style="border: 1px solid black; padding: 2px;">-- ▾</span>	<span style="border: 1px solid black; padding: 2px;">-- ▾</span>	<span style="border: 1px solid black; padding: 2px;">-- ▾</span>	<span style="border: 1px solid black; padding: 2px;">+d ▾</span>	<span style="border: 1px solid black; padding: 2px;">Ovl ▾</span>	<input style="width: 50px;" type="text" value="200"/>	<input style="width: 50px;" type="text" value="500"/>	<input type="checkbox"/>	<input type="checkbox"/>	<input type="checkbox"/>	<input checked="" type="checkbox"/>	<input type="checkbox"/>	<input type="checkbox"/>

Limits 5...8												
a	b	c	d	Type	Value	Delay	Relais					
					[N ]	[ms]	K1	K2	K3	K4	K5	K6
<span style="border: 1px solid black; padding: 2px;">+a ▾</span>	<span style="border: 1px solid black; padding: 2px;">+b ▾</span>	<span style="border: 1px solid black; padding: 2px;">-- ▾</span>	<span style="border: 1px solid black; padding: 2px;">-- ▾</span>	<span style="border: 1px solid black; padding: 2px;">Ovl ▾</span>	<input style="width: 50px;" type="text" value="400"/>	<input style="width: 50px;" type="text" value="0"/>	<input type="checkbox"/>	<input type="checkbox"/>	<input type="checkbox"/>	<input type="checkbox"/>	<input checked="" type="checkbox"/>	<input type="checkbox"/>
<span style="border: 1px solid black; padding: 2px;">-- ▾</span>	<span style="border: 1px solid black; padding: 2px;">-- ▾</span>	<span style="border: 1px solid black; padding: 2px;">+c ▾</span>	<span style="border: 1px solid black; padding: 2px;">+d ▾</span>	<span style="border: 1px solid black; padding: 2px;">Ovl ▾</span>	<input style="width: 50px;" type="text" value="400"/>	<input style="width: 50px;" type="text" value="0"/>	<input type="checkbox"/>	<input type="checkbox"/>	<input type="checkbox"/>	<input type="checkbox"/>	<input type="checkbox"/>	<input checked="" type="checkbox"/>
<span style="border: 1px solid black; padding: 2px;">+a ▾</span>	<span style="border: 1px solid black; padding: 2px;">+b ▾</span>	<span style="border: 1px solid black; padding: 2px;">+c ▾</span>	<span style="border: 1px solid black; padding: 2px;">+d ▾</span>	<span style="border: 1px solid black; padding: 2px;">Ovl ▾</span>	<input style="width: 50px;" type="text" value="800"/>	<input style="width: 50px;" type="text" value="0"/>	<input checked="" type="checkbox"/>	<input checked="" type="checkbox"/>	<input checked="" type="checkbox"/>	<input type="checkbox"/>	<input type="checkbox"/>	<input type="checkbox"/>
<span style="border: 1px solid black; padding: 2px;">-a ▾</span>	<span style="border: 1px solid black; padding: 2px;">-b ▾</span>	<span style="border: 1px solid black; padding: 2px;">-c ▾</span>	<span style="border: 1px solid black; padding: 2px;">-d ▾</span>	<span style="border: 1px solid black; padding: 2px;">Unl ▾</span>	<input style="width: 50px;" type="text" value="-800"/>	<input style="width: 50px;" type="text" value="0"/>	<input type="checkbox"/>	<input type="checkbox"/>	<input type="checkbox"/>	<input checked="" type="checkbox"/>	<input checked="" type="checkbox"/>	<input checked="" type="checkbox"/>

Copyright © 2013-2017 A.S.T. Angewandte System Technik GmbH, All rights reserved.

Figure 33 – Limits

"Enable change with dig. Inputs" allows the disabling or enabling of the limit switching by means of digital inputs 1 ... 8.





Button	
	Release of "Limits" for changes. The header "Limits active" will be displayed.
Lim it set 	Accessing to a limit set as that currently due to be edited.
	Repeated reading of limit sets and display of current values. Corresponds to Start button.
	Saving of displayed limit set in a temporary memory buffer.
	Saving of limit sets placed from the temporary memory buffer on the device and takeover of current limit set to the LS function.
	Exiting of this menu without taking over the limit values.

Table 6 – Buttons Limits

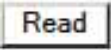
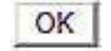

Up to a total of eight limit sets can be defined under "**Limits**".

Allocation of the contacts to the sensors takes place on flexible lines. Depending on the allocation, the contacts will open if overload conditions prevail (Type - Overload/**Ovl**) and/or if underload conditions prevail (Type - Underload/**Unl**).

Any number of individual sensors or cumulative/differential loads can be monitored. A time lag of up to 5 seconds can be entered for the opening action (inputting in ms). If the signal falls back below the switching point within this delay period, the Open command will be cancelled.

## 6.6. Load spectrum recorders (LSR)

Accessing to the “LSR” page will display the following image:

**LS804 - Configuration**

[| Status](#) | [Settings](#) | [Adjustment](#) | [Limits](#) | [LSR](#) | [Config](#) |

### Load spectrum recorder

*Theoretical values*

	Useful life D [h]	Start value S(start) [h]
Sensor a	<input type="text" value="100"/>	<input type="text" value="0"/>
Sensor b	<input type="text" value="100"/>	<input type="text" value="0"/>
Sensor c	<input type="text" value="100"/>	<input type="text" value="0"/>
Sensor d	<input type="text" value="100"/>	<input type="text" value="0"/>

*Runtime values*

	Mode	S(run) [h]	V=S(run)/D [%]
Sensor a	-	0.00	0.0
Sensor b	-	0.00	0.0
Sensor c	-	0.00	0.0
Sensor d	-	0.00	0.0

Copyright © 2013-2016 [A.S.T. Angewandte System Technik GmbH](#), All rights reserved.

Figure 34 – Load spectrum recorders (LSR)

### Theoretical values

Theoretical useful life D (Useful life) is entered in the *Theoretical values* field in respect of signals a to d as well as the starting values pertaining to actual useful life S (Start value) of the respective sensors.

The values are saved by pressing the  button.

### Runtime values

The *Runtime values* field displays the following:

Mode: RUN if one sensor is active (Raise/Lower) i.e. the useful life will be computed  
 S(run) [h]: Actual useful life  
 V=S(run)/D [%]: Consumed useful life

### 6.7. Configuration / Config

Accessing to the "Config" window makes it possible to document the current settings.

For this purpose it is necessary to press the button marked "Generate current config file". This then creates *config.txt* and *config.bin* files including the date and time stamp of the PC.

This *config.txt* file documents all relevant settings/data for operating the LS 804

The *config.bin* binary file is suitable for recovering the settings.



**Caution!** When settings undergo any change on the LS 804 the files *config.txt* and *config.bin* will be deleted and afterwards need to be recreated.

Saving the *config.txt* and *config.bin* files is performed by the user in the usual way.

Figure 35– Config.

It is possible to select a binary file by means of the button "Datei auswählen"/"Select file" and to send it to the LS 804 by pressing the "Send" button. A check is carried out of the device type and checksum of the binary file. After the binary file has been successfully loaded without any errors, the settings can be saved on the LS 804 by means of the button "Write config to device"



**Caution!** After the binary file "*config.bin*" has been saved on the LS 804, the sensors will need to be adjusted and saved (refer to Chapter 6.4 Adjustment (load calibration)). The limit values will also need to be saved (refer to Chapter 6.5. Limits (K1 to K6)).



**Note:** The length of the file name for recovery of the settings must not be allowed to exceed 31 characters.

## 7. Maintenance / Error messages

### 7.1. Status of relays K1 to K6

The status of relays K1 to K6 as well as Error1 and Error2 is queried by means of the browser, Chapter 6.2 Status (information), link "Relay status". The relay-flags window that opens displays the status of the contacts corresponding to the settings specified in Chapter 6.5 Limits (K1 to K6).

The screenshot shows the 'LS804 - Configuration' web interface. At the top right is the 'AST Gruppe' logo with the tagline 'Angewandte System Technik'. The main content area is titled 'Relais status' and contains a table with the following data:

	<i>Relais flags</i>							
	<b>K1</b>	<b>K2</b>	<b>K3</b>	<b>K4</b>	<b>K5</b>	<b>K6</b>	<b>Error1</b>	<b>Error2</b>
Relais 0=on/1=off	1	1	1	1	1	1	1	1

At the bottom of the interface, there is a copyright notice: 'Copyright © 2013-2016 A.S.T. Angewandte System Technik GmbH, All rights reserved.'

Figure 36 – Relay flags (0 - closed, 1 - open: Switching condition met in accordance with Chapter 6.5).

## 7.2. Status of relays Error1 and Error2

In the event of a system failure or similar circumstances occurring causing the LED Error to light up **red**, the error-flags window can be opened by means of the browser, Chapter 6.2 Status (information), link "Error status".

# LS804 - Configuration

### Error status

<i>Error flags - Safe (SF)</i>								
	Sens. a/c	Sens. b/d	Rsv.	Rsv.	KV-Set	KV-Err	KV-To	Rel
Channel 1	0	0	-	-	0	0	0	0
Channel 2	0	0	-	-	0	1	0	0

<i>Error flags - Hardware (HW)</i>								
	Sens. a/c	Sens. b/d	AFE	V-Exc	RAM	ROM	Osc	Wdg
Channel 1	1	0	0	1	0	0	0	0
Channel 2	0	0	0	-	0	0	0	0

<i>Error flags - Excitation / Voltage / Signal/Load cell (V-Exc)</i>								
	12V	5V	3.3V	3.3V	Sens. a	Sens. b	Sens. c	Sens. d
	Rel.	Exc/Vcc	Exc	Vcc				
	0	0	0	0	0	0	0	0

Copyright © 2013-2016 [A.S.T. Angewandte System Technik GmbH](#), All rights reserved.

Figure 37– Error-Status (0 - closed, 1 - open: Error message)

Where a system error occurs, **all** relays (K1 to K6 and Error1 / Error2) will be de-energised!



**Caution!** The LS 804 can only be returned to the operating state (LED Run lights up **green**) after the causes of failure have been eliminated and the device has been started up with key **F3** - **Reset** or input IN12.

## 8. Instructions in the event of failure

The most probable causes of failure – “Sensor errors” (Chapter 8.2. Sensor errors and “Adjustment errors” (Chapter 8.3) – will be found specified in Table 7 and Table 8. Allocation to Ch1 and Ch2 is of no importance.

### 8.1. Error overview



**Note:** Any error flags that are set are always identified by “1”, the non-fault state being indicated by a “0”.

#### 8.1.1. Error overview / Sensor errors

Code	Failure	Remedy
CH1: <b>SF:20</b> / HW:x1 CH1: <b>SF:20</b> / HW:x2	Sensor <b>a</b> : Sensor error / Very high overload Sensor <b>b</b> : Sensor error / Very high overload	Check cable connection for short-circuiting or rupture. Check sensors.
CH2: <b>SF:20</b> / HW:x1 CH2: <b>SF:20</b> / HW:x2	Sensor <b>c</b> : Sensor error / Very high overload Sensor <b>d</b> : Sensor error / Very high overload	Check cable connection for short-circuiting or rupture. Check sensors.

Table 7 – Examples of sensor errors

#### 8.1.2. Error overview: hardware failure / adjustment errors

Code	Failure	Remedy
HW:x8	Supply voltage(s) for sensors / Sensor errors.	Check cable connection for short-circuiting or rupture. Check sensors. Check supply voltages.
HW:x3	Adjustment has not attained completion for sensor <b>a and b</b> (Ch1) or <b>c and d</b> (Ch2).	Carry out adjustment (Chapter 6.4 Adjustment).
HW:x2	Adjustment has not attained completion for sensor <b>b</b> or <b>d</b> .	Carry out adjustment (Chapter 6.4 Adjustment).
HW:x1	Adjustment has not attained completion for sensor <b>a</b> or <b>c</b> .	Carry out adjustment (Chapter 6.4 Adjustment).

Table 8– Examples of hardware failure/adjustment errors

The applicable SF-values for all errors listed in Table 8 are always optional **SF=xx**.



**Note:** Communication errors involving logic units L1/L2 are atypical and are shown as **SF=00** / **HW=00** (refer to Chapter 8.4.).

The following chapters contain information on errors that occur along with their respective indications in the LCD display as well as on the status website.

## 8.2. Sensor errors

This type of error can be caused for example by wire breakage on +SI b (terminal 44).

The error is identified by **SF=xx / HW=02**.

```

F A T A L - E R R O R !
C h 1 :   S F : 0 0   /   H W : 0 2
C h 2 :   S F : 2 0   /   H W : 0 0
      I P   F l a g s       R e s e t
    
```

Figure 38 – Sensor error / Sensor b – display (error display)

Actuating key **F2** **Flags** and keys **◀** or **▶** makes it possible to display the respective sensor errors (HW flags). Any additional error occurring on the sensor supply system can be displayed by pressing key **F1** **V-Exc**.

```

H W - F l a g s
a : 0    b : 1    c : 0    d : 0
V - E x c : 0
      V - E x c           E x i t
    
```

Figure 39 – Sensor error / Sensor b – display (HW flags)

## 8.3. Adjustment errors

This type of error is caused by the device not having been adjusted or following deletion of an adjustment or as a result of the adjustment of sensors a to d not having been carried out or completed.

The error is identified for example by **SF=xx / HW=01**.

```

R u n - A d j . n o t O K !
a :      2 0 . 4   t
b :      1 . 5   t
      E r r       c / d       R e s e t
    
```

Figure 40 – Adjustment error / Start – display (measured-value display)

By actuating key **F1** **Err** it is possible to display the error information on the individual sensors a to d (refer to Chapter 7.1).

```

H W - F l a g s
a : 1    b : 0    c : 1    d : 0
                        E x i t
    
```

Figure 41 – Adjustment error / Display (error display)

<u>Error status</u>			
Comm. - Channel 1	<b>Error</b>	/ SF=00	HW=01
Comm. - Channel 2	<b>Error</b>	/ SF=00	HW=01
<u>Relais status</u>			
Relais	RelOut=FF	RelIn=FF	

Figure 42– Adjustment error / Start – Status

After the adjustment function has been accessed to, the LCD will indicate whether adjustment is erroneous or free of errors.

<b>A d j u s t m e n t</b>
<b>A d j u s t m e n t n o t O K !</b>
<b>E x i t</b>

Figure 43 – Adjustment erroneous

<b>A d j u s t m e n t</b>
<b>A d j u s t m e n t O K !</b>
<b>E x i t</b>

Figure 44 – Adjustment free of errors

#### 8.4. Communication errors / Logic units L1/L2

This type of error is caused by faults occurring in communication with the logic units L1/L2 (Ch1/Ch2).

The error is identified by an error message **SF=00 / HW=00**.

<b>S t a r t - E R R O R !</b>
<b>C h 1 : S F : 0 0 / H W : 0 0</b>
<b>C h 2 : S F : 0 0 / H W : 0 0</b>
<b>R e s e t</b>

Figure 45 – Communication error – Display (Error display)

<u>Error status</u>			
Comm. - Channel 1	<b>Error comm.</b>	/ SF=00	HW=00
Comm. - Channel 2	<b>Error comm.</b>	/ SF=00	HW=00
<u>Relais status</u>			
Relais	RelOut=00	RelIn=00	

Figure 46 – Communication error – Status

If the error continues to occur after a “Reset”, this points to a hardware defect on one or both of the logic units L1/L2.

## 9. Technical data

Sensor inputs		LS 804.01 for DMS sensors	LS 804.02 for 4 ... 20mA sensors
Input signal range (+Si/-Si) Impedance range for DMS bridge. Supply voltage for DMS bridge (+Ex/-Ex) Conversation rate ADU	VDC Sps	-5.0mV/V ... +5.0mV/V Bridge resistance: 350 ... 1000 Ω 5.0 / 3.3 480	4mA ... 20mA Max. load: 25mA/sensor 24 ± 10% 480
Voltage supply		LED display	
Operating voltage Power consumption Connection terminals	VDC W mm <sup>2</sup>	18 ... 36 max. 15 Screw terminal up to 1.5	
Switching inputs Schalteingänge IN 1 ... 16		LED display	
Optocoupler groups 4 x 4 Return lines using plug-in jumpers "IN__R" Connection terminals	mm <sup>2</sup>	"direct" or "+24VDC" or "0V" Screw terminal up to 1.0	
Switching outputs K1 ... 6 and Error 1...2		LED display	
Normally open contacts, force-guided Switching voltage / switching current Switching capacity Datarate Service life – electrical Service life – mechanical Connection terminals	1/ s  mm <sup>2</sup>	DC1: 24V/2A DIN EN 60947-4-1 and 60947-5-1 60mW ... 50 W(VA) 80 100,000 switching cycles > 10 mill. switching cycles Screw terminal up to 1.5	
Analogue outputs		LED display	
2x current outputs / max. load OR 2x voltage outputs / min load Datarate Connection terminals	mA / Ω  V / kΩ 1/ s mm <sup>2</sup>	4mA ... 20mA/ 350Ω  0V ... 10V/ 1kΩ 20 Screw terminal up to 1.0	
Digitale Schnittstellen		LED display	
Ethernet CAN RS485		RJ45 9-pole SUB-D 9-pole SUB-D	
Load spectrum recorders - LSR		LED display	
Input values Time basis Output values	h  h	D: Theoretical useful life S: starting value, consumed useful life 1/3600 Indication in display	
Display / keypad		LED display	
Display Lamps Keypad		4-line LED display, 16 characters per line 7 LED status displays Membrane keypad: Cursor cross, three function keys F1 ... F3	
Ambient conditions		LED display	
Working temperature range Storage temperature range	°C °C	-20 ... +60, relative humidity <95% at 40°C -25 ... +70, relative humidity <95% at 40°C	
Interference immunity Interference emission Vibration resistance Impact resistance		DIN EN 61000-6-2 DIN EN 55011-B DIN EN 60068-2-6 DIN EN 60068-2-27/-29	
Design data		LED display	
Weight Dimensions (W x H x D) Mounting Environmental protection EN 60529	kg mm	1 102 x 105 x 205 on mounting rail TS35 IP 40	

## 10. Project planning assistance

<b>Settings (scalings)</b>		<b>Sensor a</b>	<b>Sensor b</b>	<b>Sensor c</b>	<b>Sensor d</b>
Meas. scale set.	Signal used				
	Final Value (100% Load)				

<b>AnalogOut 1/2</b>		<b>Type</b> (4...20mA od. +/-10V)	<b>Signal</b> (a,b,c,d, $\Sigma a+b$ , $\Sigma c+d$ , $\Sigma a-d$ )
	Analogue output 1		
	Analogue output 2		

<b>Adjustment (adjustment)</b>		<b>Sensor a</b>	<b>Sensor b</b>	<b>Sensor c</b>	<b>Sensor d</b>
Sensor characteristics	Input sensitivity (mV/V oder mA)				
Load calibration	Zero load (no entry)				
	Test load				

<b>Limits (switching points)</b>	<b>Term (+/- a/b/c/d)</b>	<b>Type (Ovi Unl)</b>	<b>Value (Unit)</b>	<b>Delay (ms)</b>	<b>K1</b>	<b>K2</b>	<b>K3</b>	<b>K4</b>	<b>K5</b>	<b>K6</b>
Limit 1										
Limit 2										
Limit 3										
Limit 4										
Limit 5										
Limit 6										
Limit 7										
Limit 8										

<b>LSR (load spectrum recorders)</b>		<b>Sensor a</b>	<b>Sensor b</b>	<b>Sensor c</b>	<b>Sensor d</b>
	Theoretical useful life D (h)				
	Starting value / actual useful life S (h)				

## 11. EC declaration of conformity

**A.S.T. - Angewandte System Technik GmbH**  
Mess- und Regeltechnik



# EG-Konformitätserklärung EC Declaration of Conformity

No. 16/16

Hersteller: A.S.T. - Angewandte System Technik GmbH  
Manufacturer: Mess- und Regeltechnik

Anschrift: Marschnerstraße 26, 01307 Dresden  
Adress: Bundesrepublik Deutschland

Produkt-  
bezeichnung: Lastschalter LS 804  
Product description: Load switch LS 804

Das bezeichnete Produkt stimmt in der von uns in Verkehr gebrachten Ausführung mit den Vorschriften folgender Europäischer Richtlinien überein:  
The product described above in the form as delivered is in conformity with the provisions of the following European Directives:

2014/30/EU Richtlinie des Rates zur Angleichung der Rechtsvorschriften der Mitgliedsstaaten über die elektromagnetische Verträglichkeit.  
Council Directive on the approximation of the laws of the Member States relating to electromagnetic compatibility.

Die Konformität mit der Richtlinie 2004/108/EG wird nachgewiesen durch die Einhaltung folgender harmonisierter Normen:  
Conformity to the Directive 2004/108/EC is assured through the application of the following harmonised standards:

Störfestigkeit: Interference resistance:	DIN EN 61000-6-2:2006-03
Störaussendung: Emitted interference:	DIN EN 61000-6-3:2011-09

Dresden, den 04.08.2016

gez. Dr.-Ing. Gerd Heinrich  
Qualitätssicherung / Quality assurance

A.S.T. - Angewandte System Technik GmbH  
Mess- und Regeltechnik  
Marschnerstraße 26, D-01307 Dresden

<http://www.ast.de>  
Tel (0351) 44 55 30  
Fax (0351) 4455-451

Geschäftsführer:  
Matthias Boeck  
HRB-Nr.: 5910  
Kreisgericht  
Dresden

Bankverbindung:  
Ostsächsische  
Sparkasse Dresden  
BLZ 850 503 00  
Konto 3120 1040 93